

PA28-181 Checklist N6817J



PREFLIGHT	
Weather	Density Altitude
Weight & Balance	Flight Plan
Frequencies & Phone #s	
Papers: AROW (Airworthiness, Registration, Op. Limits, Weight and Balance), Pilot Cert, Current Medical	
EXTERIOR	
Cockpit:	
Ignition	OFF, Key Removed
Master Switch	ON
Avionics Master	ON
Light Switches (Nav, Strobe, Beacon, Landing)	ON
Pitot Heat	ON
Hobbs/Tach	Record Time
Walk around and check lights, pitot heat, stall warning	
Light Switches (Nav, Strobe, Beacon, Landing)	OFF
Pitot Heat	OFF
Avionics Master	OFF
Master	OFF
Flaps	Check operating range, EXTENDED
Walk around:	
RIGHT WING	
Flaps and Ailerons	CHECK
Wing Tip	CHECK
Wing Tie-down	DISCONNECT
Fuel Tank Vent	CHECK
Fuel Quantity	CHECK VISUALLY
Fuel Tank Sump	CHECK
Main Landing Gear (Tire 24 psi)	CHECK
NOSE	
Engine Oil Level	Oil 6-8 qts **Do not over tighten cap**
Carburetor Air Inlet	CHECK
Propeller and Spinner	CHECK

PA28-181 Checklist N6817J



Alternator Belt	CHECK
Nose Landing Gear (Tire 18 psi)	CHECK
Fuel Strainer	CHECK
LEFT WING	
Fuel Tank Sump	CHECK
Main Landing Gear (Tire 24 psi)	CHECK
Fuel Tank Vent	CHECK
Wing Tie-down	DISCONNECT
Fuel Quantity	CHECK
Wing Tip	CHECK
Aileron and Flaps	CHECK
EMPENNAGE	
Stabilator and Rudder	CHECK
Trim Tab	CHECK
Tail Tie Down	Remove

BEFORE STARTING ENGINE	
Brakes	Set
Passenger Brief	Complete (SAFETY)
Seat Tracks	Secure
Belts/Harness	Secure
Loose Items	Secure

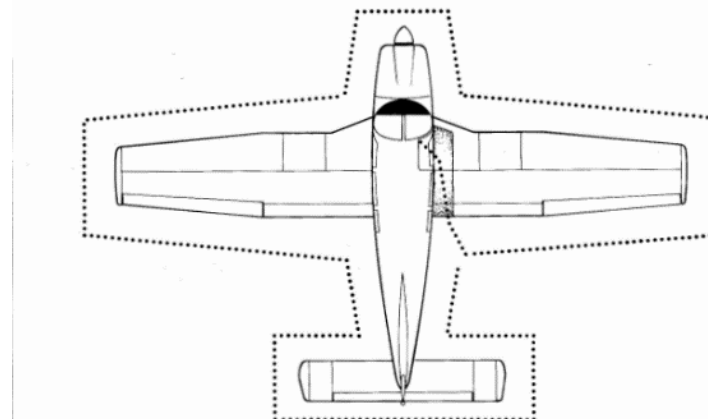

PA28-181 Checklist

N6817J



ENGINE START	
Flap	RETRACTED
Master Switch	ON
Circuit Breakers	CHECK IN
Carb Heat	OFF
Anti-Collision Lights	ON
Electric Fuel Pump	ON
Throttle	Closed
Mixture	Rich
Fuel Selector	Fullest Tank
Throttle	Pump as needed then open 1/8 inch
Prop Area	CLEAR PROP
Ignition Switch	ON
Throttle	Adjust to 800-1000 RPM, lean for taxi
Oil Pressure	Check GREEN
Ammeter	Check
Fuel Pump	OFF
Avionics Master Switch	ON
Transponder	Standby and VFR

PRE-RUN UP	
Avionics/Radios	On/Set Frequencies
Transponder	ALT
ATIS/AWOS	Listen/Notes
Altimeter	Set
Test and Set:	Brakes, Compass, Altitude, Heading and Turn Indicators, and Inclinometer
Landing/Taxi Lights	As Required
Taxi Area	Clear

PA28-181 Checklist

N6817J



RUN-UP	
Brakes	Set and Hold
Cabin Doors	Closed and Latched
Flight Controls	Free and Correct
Primer	In and Locked
Fuel Selector	Fullest Tank, Quantity OK
Elevator and Rudder Trim	Set for Take Off
Fuel Pump	ON
Mixture	Rich or as appropriate
Throttle	2000 RPM
Check:	MAGS – R, B, L, B (Up to 175 RPM drop in either or 50 RPM differential) CARB HEAT Amps/Volts – In Green Oil Pressure and Temp – In GREEN
Annunciator Panel	Press to Test
Throttle	Check idle, 800-1000 RPM
Fuel Pump	OFF
Transponder	ALT
Flight Plan	Set

PA28-181 Checklist

N6817J



BEFORE TAKE OFF	
Radio Frequency	CHECK
Mixture	Full Rich
Lights	As required
Electric Fuel Pump	ON, Pressure OK
Take Off and Abort Plan	Complete
Traffic	Check

FLIGHT	
NORMAL TAKE OFF	
Flaps and Trim	10° and take off
Elevator Normal Climb Out Vy	Rotate at 60 KIAS 76 KIAS
Flaps	Retract slowly at safe altitude

SHORT FIELD TAKE OFF	
Flaps	25°
Elevator Initial Climb Speed Vx Climb Speed Vy	Rotate at 55 KIAS 64 KIAS until clear 50' obstacle 76 KIAS
Flaps	Retract slowly at safe altitude

SOFT FIELD TAKE OFF	
Flaps	25°
Elevator Initial Climb Speed Vx Climb Speed Vy	Rotate at a controllable airspeed 64 KIAS until clear 50' obstacle 76 KIAS
Flaps	Retract slowly at safe altitude

CLIMB	
Airspeed	76-87 KIAS
Throttle	Full Open
Mixture	Rich
Engine Instruments	Check
Landing/Taxi Lights	As required

PA28-181 Checklist

N6817J



CRUISE	
Throttle	As needed (75% power)
Mixture	Lean
Elevator and Rudder Trim	Adjust as needed
Fuel	Change Tanks as Required -Fuel pump ON -Switch tanks -Fuel pump OFF -Verify proper indications
Electric Fuel Pump	Off (On when changing tanks)
Engine and Flight Instruments	Check
Heading Indicator	Adjust to Compass

DESCENT	
Mixture	Adjust as needed
CARB Heat	As Required
Pitot Heat	As Required
ATIS/AWOS	Listen
Altimeter	Set
Landing/Taxi Lights	As Required

LANDING CHECKLIST	
Brakes	Pressure in Pedals
CARB Heat	ON
Landing/Taxi Lights	ON
Electric Fuel Pump	ON
Mixture, Master, Mags	RICH, ON, BOTH
Fuel Selector	Fullest Tank
Oil	Pressure and Temp OK
Hatches and Harnesses	Secure and Tighten

LANDING	
Extend Flaps	As Required
Normal	66 KIAS
Soft Field	60 KIAS
Short Field	60 KIAS
Brakes	As required

PA28-181 Checklist

N6817J



GO AROUND	
Throttle	Full OPEN
CARB Heat	OFF
Airspeed Vx	64 KIAS
Flaps	Retract Slowly

AFTER LANDING	
Radio Frequency	CHECK
Flaps	RETRACTED
CARB Heat	OFF
Landing/Taxi Lights	As Required
Electric Fuel Pump	OFF
Trim	Set for Take Off

SHUT DOWN	
Hobbs/Tach	Record
Avionics/Electrical Switches	OFF
Mixture	Idle Cut Off
Master Switch	OFF
Ignition Switch	OFF, Key Out
Secure	Chocks/Tie Downs Hangar Door Closed and Locked

PA28-181 Checklist

N6817J



EMERGENCY PROCEDURES	
Best Glide: 76 kts	Radios 121.5 Squawk 7700
ENGINE FAILURE DURING FLIGHT (Restart Procedures)	
Airspeed Vg	76kts
Place to land	Locate
Carb Heat	ON
Fuel	Switch Tanks
Fuel Pump	ON
Magneto	CHECK
Throttle	SWEEP
Mixture	FULL RICH/SWEEP
Primer	LOCKED
Engine Gauges	CHECK
Declare Emergency	7700 / 121.5
If no restart, secure aircraft for landing	
Seatbelts	TIGHTEN
Doors	UNLATCH
FUEL	OFF
Fuel Pump	OFF
Throttle/Mixture	IDLE/CUT OFF
Magnetos	OFF
Master Switch	OFF
Flaps	AS NEEDED
ENGINE FIRE DURING START	
Starter	Keep Cranking
Mixture	IDLE CUT-OFF
Throttle	FULL OPEN
Fuel Pump	OFF
Fuel Selector	OFF

**PA28-181 Checklist
N6817J**



**PA28-181 Checklist
N6817J**



EMERGENCY PROCEDURES	
Best Glide: 76 kts Radios 121.5 Squawk 7700	
FIRE DURING FLIGHT	
Source of fire	CHECK
Electrical (Smoke in Cabin)	
Master Switch	OFF
Vents	OPEN
Cabin Heat	OFF
Land as soon as practical	
Engine Fire	
Fuel Selector	OFF
Throttle	CLOSED
Mixture	IDLE CUT-OFF
Fuel Pump	OFF
Heater & Defrost	OFF
Emergency Decent	Execute (High airspeed to extinguish fire)
DO NOT ATTEMPT RESTART	